



FALLS FORUM

MAY 2026

4200 Lakeridge Boulevard
Sarasota, FL 34243

www.lakeridgefalls.org



A PICTURE BY TONY SCACIFERO

A Message from Your Board...Thinking Ahead, Working Together

Rod Hayden, President

May feels like a turning point. Here at LakeRidge Falls, that seems especially true this year as we just celebrated our 25th anniversary as a community association. Twenty-five years is no small thing. The world has changed a lot in that time. Life moves faster. Technology touches almost everything we do. But the things that matter most in a community like ours have not changed nearly as much: being good neighbors, taking pride in where we live, and working together when it counts.

That same spirit was behind our first Town Hall on March 25. It was a new step for the Board, and I think it was a worthwhile one. It gave residents another way to bring concerns to the board in a more informal setting. It's another useful way to listen and stay in touch with the community's pulse. Thank you to those who attended and gave it a chance.

This is also the season when things begin to quiet down a bit. Many of our neighbors are heading north for the summer, and we wish them safe travels, good health, and a wonderful season ahead. We will look forward to seeing you back here before too long.

At the same time, community life here continues to evolve. New ideas are taking shape, including the early energy behind the New Waves group and its interest in lifelong learning and fresh programming. Even after 25 years, LakeRidge Falls is still finding new ways to grow.

That is how good communities stay strong — not by standing still, but by staying connected and neighborly.

Association Info

COMMITTEES

Architectural Review Board (ARB)

Mr. Jerry Brantley, Board Liaison
Chairperson - Mrs. Mary Cochran
Meetings: Second Thursday of the month at 10:00 am

Budget Committee

Mr. Jerry Brantley, Board Liaison
Chairperson - TBD
Meetings: TBD

Buildings Committee

Ms. Lori Klein, Board Liaison
Chairperson - Ms. Maria Herrmann
Meetings: Second Thursday of the month at 9:00 am

Community Relations Committee (CRC)

Mrs. Linda Cowett, Board Liaison
Chairpersons - Mrs. Sue Selvidio-Stanley & Mrs. Jolene Ruffo
Meetings: Third Friday of the month at 10:30 am

Landscape Committee

Mrs. Linda Cowett, Board Liaison
Chairperson - Ms. Annmarie Locascio
Meetings: First Tuesday of the month at 10:00 am

Pool Committee

Mr. Wayne Johnson, Board Liaison
Co-Chairperson - Mrs. Linda Lorenz & Mrs. Fern Rouleau
Meetings: Forth Wednesday of the month at 10:00 am

Roads & Grounds (R&G) Committee

Mr. Wayne Johnson, Board Liaison
Chairperson - Mr. Paul Hoffman
Meetings: Second Tuesday of the month at 11:00 am

Security Committee

Ms. Lori Klein, Board Liaison
CO-Chairpersons - Mr. Guenter Lorenz & Mr. Dan Meintel
Meetings: Third Thursday of each month at 10:00 am

BOARD OF DIRECTORS

President, Rod Hayden, President@lakeridgefalls.org
Vice President, Wayne Johnson, VP@lakeridgefalls.org
Treasurer, Jerry Brantley, Treasurer@lakeridgefalls.org
Secretary, Lori Klein, Secretary@lakeridgefalls.org
Director at Large, Linda Cowett, DirectorAtLarge@lakeridgefalls.org

OFFICE

Community Manager: Oded Neeman
Phone: 941-360-1046
Email: PropertyManager@LakeRidgeFalls.org
After hours Emergency Only: 941-444-7090

GATEHOUSE

Captain: Peter Palladino
Phone: 941-355-1328
Email: Security@LakeRidgeFalls.Org

COMMITTEES - CONT'D

Art League

Mrs. Becky Stevens, President
Meetings: Second Monday of the month at 1:30 pm

Social Committee

Mrs. Fern Rouleau & Ms. Leigh Salby, Co-Chairpersons
Meetings: First Monday of the month at 10:00 am

BRIGHT REALTY

THE ROTHSCHILD TEAM
REAL ESTATE AGENTS
www.LiveSarasota.com

**We lived in LRF
We Know LRF**

Leslie
☎ (941) 266-5308
✉ lroths3124@gmail.com

Irv
☎ (941) 321-9683

The advertisement features a circular portrait of Leslie and Irv, a background image of a tropical beach with palm trees, and a logo for Bright Realty. The text is arranged in a clean, professional layout with contact details for both agents.



Last month the Art League sent out four checks for \$150.00 each to support scholarships for Kids Summer Art Camps. The institutions receiving the checks are Art Center Sarasota, Herrig Center for the Arts in Bradenton, Boys and Girls Clubs of Sarasota and Manatee Counties. We thank all of you who give donations at our Art Receptions and those who just write a check whenever it is convenient, in any amount. We feel it is important to support the next generation of artists. Thank you for your help.

We would like to express our thanks to the Garage Sale committee for gifting us \$25.00 from the unspent money they collected for Garage Sale expenses. We will discuss how to use it at our next meeting.

The Art League is currently offering Watercolor Classes on Wednesday mornings. A new four week session will begin on April 29th. Cost will be \$100.00 for all four classes. Contact Becky Stevens about supplies if you are interested stevensreb@gmail.com or 941-359-1765



Always Know
Value Matters

Call Today
941.727.3996

EXCEPTIONAL SERVICE, RELIABLE WORK

- The Preferred Roofing Company by many of LakeRidge Falls Members
- Rated 4.9 Stars On Google
- BBB Accredited (A+ Rating)
 - Tile Roof Experts
- Locally Owned & Operated



CCC1328176
Roofing

ROOFING COMPANY

CBC1258181
Building

WOMEN'S BREAKFAST & DINING DIVAS

Please Join us! We are having Breakfasts and Lunches at different places each month during the entire year. Our dates are the 3rd Tuesday of the month for Breakfasts and Lunches at the 1st Friday of the month. Come meet your neighbor, bring a fellow neighbor, chat with old friends and make new friends. Please sign up on the clubhouse bulletin board. If you have a favorite place for lunch or breakfast please call us at 941-360-1457 or email to irenebill1978@verizon.net



DINING DIVAS

MAY 5 @ 11:30AM
7671 THE PARK BLVD,
UNIVERSITY PARK, FL 34201-2201

WOMEN'S

BREAKFAST-MAY 19 @ 9:30AM

**6056 LOCKWOOD RIDGE RD,
SARASOTA, FL 34243**



RESIDENTS' CORNER



Mackay Falls Street Party



GOOD TIMES

PLAY BALL! BOCCE BALL THAT IS!

LakeRidge Falls

Bocce Ball Party

FRIDAY, APRIL 17TH

Bocce Ball is a game for the generations – especially here in LakeRidge Falls. We have a great time learning and playing the game: roll the small pallino and take turns rolling larger colored balls to see which team comes closest to the pallino. Everyone can play, regardless of ability or age. Ask any of us who play Bocce on Monday, Wednesday and Friday mornings at 9:00 AM why we play. We'll ALL tell you the same thing – we have FUN and enjoy each other!

Before the Snowbirds fly north, it has become a LRF tradition to have an "end of the winter season" party. Below are just a few of the photos from the party on 4/17. And a "Good time was had by all." So why not join us? New players are always welcome.



THE BOARD OF DIRECTORS WANTED TO SAY A BIG THANK YOU TO MR. RON OTT, A LONG-TIME MEMBER OF THE COMMUNITY, WHO DONATED A HANDMADE, WOOD-CRAFTED, DELUXE POOL CUES WALL RACK. IT WILL BE UNFAIR TO DESCRIBE THE CRAFTSMANSHIP OF MR. OTT AND HIS GENEROSITY IN WORDS, SO WE WILL LET A PICTURE DO ALL THE TALKING. WE ARE SURE ALL WOULD JOIN US IN THANKING MR. OTT FOR HIS AMAZING WORK AND DONATION.

COMMUNITY MANAGER REPORT - ODED NEEMAN

WATERFALL OPERATING HOURS – Thanks to a report by a long-time member of the community, it was brought to the Association’s attention that newer and tighter water restrictions took effect in April. On March 24 , the Southwest Florida Water Management District (SWFWMD), a state government agency responsible for managing water resources, declared a Modified Phase 3 “Extreme” Water Shortage.

On its website, SWFWMD advised that “[t]he restrictions apply to all of Citrus, DeSoto, Hardee, Hernando, Hillsborough, Manatee, Pasco, Pinellas, Polk, Sarasota... from April 3, 2026, through July 1, 2026.” Furthermore, SWFWMD explained these areas “received below average rainfall during its summer rainy season and currently has a 13.7-inch regional rainfall deficit compared to the average 12-month total. In addition, water levels in the District’s water resources, such as aquifers, rivers and lakes, are continuing to decline and many are severely abnormal. Moreover, public water supplies are extremely low for this time of the year.”

The main impact of the new restrictions on the Association relates to the operation of the waterfall. It is stated that “[a]esthetic fountains are limited to four hours a day. The regular hours of operation can be selected by the owner but must be posted.” Therefore, and to comply with this restriction, the Board of Directors directed the waterfall maintenance company to limit the operation of the waterfall to 9 a.m. until 1 p.m. With this in mind, and because some of the restrictions apply to individual residents, we urge all to take a moment and read about this matter by using the following link:

<https://www.swfwmd.state.fl.us/thenewsroom/2026/district-declares-modified-phase-iii-water-shortage>

As before, thank you in advance for your understanding and cooperation in this important matter.

TOO COLD TO TAKE A SHOWER – Those who used the pool a few weeks back, surely noticed that it took a long time until the hot water at the pool shower came on. Here is the full story and how it was resolved. As one can imagine, the hot water to the pool shower is being supplied by a tank water heater that is located in the Fire Alarm Control Panel (FACP)/Utility Room located at the Annex Building. As can be seen in the pictures below, this electric water heater with the thermal expansion tank mounted on top was demonstrating signs of wear. The green layer on the copper pipe is Patina, similar to the layer on the Statue of Liberty, which forms when moisture, oxygen, and copper are mixed. The significant layer, we were told, indicated that water was leaking down at a very slow rate from the fitting or maybe the copper line itself, i.e., a pinhole. The rusted fitting at the bottom of the copper line going to the water heater, well, does not need much explanation.

Because this condition meant that the tank could fail at any moment, the Board of Directors took immediate action by obtaining two quotes and thereafter selected Professional Plumbing, a well-known and reputable local plumbing company, to replace the tank. And indeed, a couple of their plumbers were on-site to replace the water heater, as can be seen in the after picture. After it was installed, they reported all was in good working order... or so they thought...

During one of the weekends, because after all the weekend is when Murphy from Murphy Law kicks in, reports came in that



the pool shower does not have hot water. Upon further inspection by Professional Plumbing on two different occasions, the pool shower did have hot water, but it took a few minutes before they came out. To some extent, this is similar to the phenomenon one may experience at home in the shower located the farthest from the water heater. Knowing that, it was clear that one of two things may happen: a clogged line or an issue with the circulation pump. Let's start with the latest.

In order to ensure the pool shower instantly receives hot water, a circulation pump was installed. In simple and nonprofessional terms, the pumps push the water down the line faster through the pipe to provide instant hot water to far points, such as the shower in your master bathroom. Therefore, Professional Plumbing suggested replacing the 20-year-old circulation pump. That said, a question must be raised. If the shower had water instead before the water tank was replaced, what happened to the circulation pump all of a sudden? The answer may be that there is a clog somewhere along the line. It is possible that during the replacement of the tank, sediment or other types of debris flew through the line, clogging it somewhere. If this is the case, then hot water "meets" a barrier, which causes this matter.

After further consideration of whether to simply replace the pump or seek a diagnostic to locate a potential clog, a decision was made to replace the pump, which proved to be the right decision. Professional Plumbing successfully completed the task, and thereafter it was said the system is working up to par, and pool users once again could enjoy hot water before and after entering the pool.

PALMS – As you may know, , we recently concluded trimming all the queen palms in the community. However, the purpose article is not to advise what has already happened, but to remind all of the unfortunate future of what will happen. As reported at least half a dozen times in the past, the consensus among professionals and scholars is that due to climate change impacts, the vulnerability of palm species may leave Florida palmless within a few decades. Two of the more well-known diseases are Ganoderma and Lethal Bronzing.

In a document titled "Ganoderma Butt Rot of Palms," Monica L. Elliott and Timothy K. Broschat of the University of Florida describe Ganoderma as a fungus that "degrades the lignin in the lower 4–5 feet of the [palm's] trunk." As they also describe, a "palm cannot be diagnosed with Ganoderma butt rot until the basidiocarp (conk) forms on the trunk, or the internal discoloration of the trunk is observed after the palm is cut down." They conclude by saying there are "currently no cultural or chemical controls for preventing the disease or for curing the disease once the palm is infected." In sum, using simple terms, Ganoderma is a palm disease that can't be prevented or treated and can only be diagnosed after it is too late. To read more about Ganoderma, please use visit the following web address: **<https://ask.ifas.ufl.edu/publication/PP100?downloadOpen=true>**

The other lethal disease is called Texas Phoenix Palm Decline, or as it has come to be known, Lethal Bronzing. In a similar document published on the University of Florida's website titled "Lethal Bronzing Disease," Brian W. Bahder and Ericka E. Helmick describe it as a type of bacterium that lives "in the part of the plant where sap is transported." Because the bacterium is "transmitted to plants by piercing-sucking insects that feed on the sap," prevention is a challenging task. They conclude by saying that "current data suggests that once palms start showing symptoms, the label rate for the antibiotic oxytetracycline-hydrochloride is not sufficient for symptom reversal." For this reason, the recommendation is that "once a palm shows symptoms and tests positive for the LBD phytoplasma [Lethal Bronzing], it should be removed immediately." To read more about Lethal Bronzing, please use visit the following web address: **<https://ask.ifas.ufl.edu/publication/PP163?downloadOpen=true>**

Adding to the mix, the average life span of a queen palm is 30 years, which is the age of the palms in the community (i.e., they were around 5 years when installed by the developer), and one can reasonably conclude that this issue significantly impacts LakeRidge Falls. Here is a simple example. In 2023, the Association had 443 queen palms. In 2026, however, this number dropped to 336, which is

almost a loss of 25% of all of the Association queen palms within only three years. Unfortunately, this rapid trends continue, as can be seen in the picture below, as more and more queens are dying.

The good news, however, is that the Association is well prepared to deal with this unfortunate reality. Some may not be aware of the fact that the idea behind the creation of the Long-Term Landscape Group sparked back in 2015 after the Association learned most of its Queen and Chinese Fan palms were infected with Ganoderma. In other words, since 2016, the Association has been continually working to ensure it has an action plan and funds set aside to address this matter by replacing the palms with more disease-resistant palms, hardwood trees such as shady ladies, and a complete landscape bed makeover of beds that were dominated by palms.

Rest assured, we will make every effort to replace all dead queen palms in the community as part of our ongoing commitment to maintaining a healthy and vibrant landscape. With this promise in mind, we wish to thank all for their understanding and patience on this subject matter.



CROTONS AND OTHER DEAD PLANTS – Staying with landscaping matters, more and more service requests are coming from residents requesting to replace one “dead shrub” or another. In the vast majority of cases, the identified plant is one variety or another of a croton. On its website, the UF/IFAS Extension, an educational entity composed of the University of Florida, the USDA, and the various county governments of Florida, advises that corton draws **“...attention with its stunning color and make a bold statement in your house or yard.”**

But despite these recent concerns about the health of the croton plants, it is important to recognize that the community’s crotons can be resilient and capable of bouncing back after periods of stress. Crotons may lose all of their leaves, making many believe they are dead or dying. However, with warmer temperatures and consistent watering, these vibrant plants typically begin to produce new growth and restore their colorful foliage.



Residents are encouraged to give crotons time to recover and avoid attempting to remove, trim, and/or fertilize them. With patience and attentive landscaping practices, crotons will once again enhance the beauty of LakeRidge Falls.

PAINTING OF MAILBOXES – As some may know, the Association concluded painting all 399 mailboxes in the community. Here is why. Back in 2013, the Association assumed the responsibility for painting all 399 mailboxes in the community, including the posts and flags. The rationale behind the decision, besides the obvious economic scale reason, is to ensure a harmonized look throughout the community. As with the case of the cleaning of the driveways and the sidewalks, the Association discovered that when homeowners are painting their mailboxes on different schedules, there is a negative impact on the Association's general appeal. In addition, the fact that homeowners are using different products, for example, glossy vs. matte look. And indeed, it is hard to miss the significant impact the work performed by Mr. Tamas Pataki has on the general look of the community.

It is important to note that while the Association is responsible for painting all mailboxes, the ongoing maintenance of the mailboxes, posts, brackets, post numbers, and flags remains the responsibility of individual residents. Homeowners should ensure their mailbox components are kept in good condition. If your mailbox does not close properly or does not have a flag, for example, it is your responsibility to repair or replace the mailbox. Furthermore, if you have an unapproved mailbox, such as plastic, large, etc., you will be required to replace it with the appropriate one, as can be seen in the picture below and measurements below. Therefore, we kindly ask all homeowners to be proactive on this matter. Thank you so much for your attention and assistance in this matter.

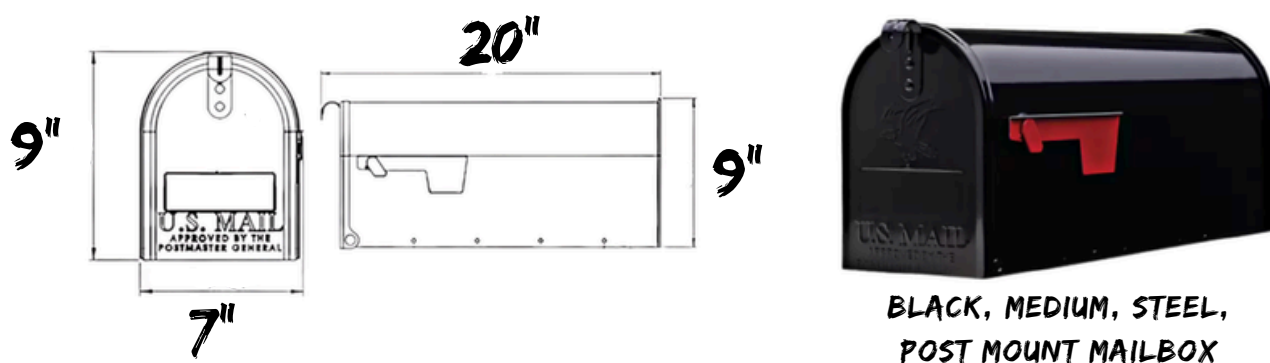

UPDATED COMMITTEE STRUCTURE POLICY – During one of its recent meetings, the Board of Directors approved a revised Committee Structure Policy. As you may know, the Board of Directors adopted a few years back a policy that laid out the structure, authority, and responsibility of the Association's committees. Since then, the various Boards of Directors gained valuable knowledge, which led them to the realization that some adjustments needed to be adopted to promote participation, efficiency, and productivity.

Therefore, to ensure there is a quorum during committee meetings, hence ensuring a committee meeting can take place, the Board added the following bulletin to the current policy: ***"Two consecutive absences from duly called committee meetings, without advance notice, will be deemed a resignation from the committee."***

With this in mind, we urge all members and residents to take a moment and read the entire revised policy. A copy of this policy is available on the Association website and on the Association portal. Furthermore, please remember that committees play a vital role in the operation of LakeRidge Falls. It is, therefore, that we encourage all to join one of the Association's committees. Remember, volunteering helps to ensure this community remains one of the best communities to live in both Manatee and Sarasota Counties.

Four Florida FOODIES Restaurant Ratings

Ratings by Fern & Bob Rouleau and Linda & Gunner Lorenz. These are our opinions for the particular day and time we went, which may change with different chefs and/or servers on a different day. In fact we HAVE found that the food has varied and would get different grades on different days, even ones we loved.



Mad Moe's Pub and Grill - B+

106 N Tamiami Trail, Osprey

- Good atmosphere
- Varied menu
- Good service
- Good prices
- Food fresh and delicious

Roman SQ Pizzeria - C+

6670 Superior Ave, Sarasota

- You point to the pizza slices you want
- Clean place
- Pizza is ok

Saigon Grill - B

6400 Tamiami Trail S, Sarasota

- Nice and clean with 8 tables
- Regular Vietnamese fare
- Quick service
- Relaxed atmosphere
- Pho noodles - med or lg bowls

Deep Lagoon - A

1540 Lakefront Drive, Lakewood Ranch

- Quick service
- Gorgeous view
- Outside and inside tables
- Excellent food
- Lunches are wonderful
- Dinners are more \$\$ but larger

Allswell Craft Cocktails and Kitchen - A

7500 Island Cove Terrace, Sarasota

- Inside and outside eating
- Very pretty interior
- Good service
- Nice bar
- Food was delicious
- Petite mignon was tender
- Fries were excellent
- Menu is limited

BOOK CLUBS

WINE AND FICTION BOOK CLUB

Count the Ways
by **Joyce Maynard**

May 26th
7:00 PM
Grand Salon



Eleanor and Cam meet at a crafts fair in Vermont in the early 1970s. She's an artist and writer; he makes wooden bowls. Within four years they are parents to three children, two daughters and a red-headed son who fills his pockets with rocks, plays the violin and talks to God. To Eleanor, their New Hampshire farm provides everything she always wanted. They are a family. After a terrible accident Eleanor is consumed by bitterness about the accident while Cam finds solace in a new, younger partner. Over the decades that follow, the members of this fractured family make surprising discoveries and decisions. Tracing the course of their lives—through the gender transition of one child and another's choice to completely break with her mother, the family is forced to confront essential, painful truths of its past, and find redemption in its darkest hours.

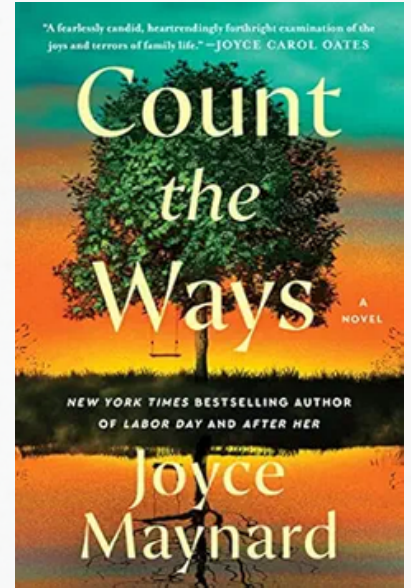

Please plan to join us for an interesting and lively discussion led by Fern Rouleau on TUESDAY, MAY 26th – 7:00 PM in the Grand Salon. New members are always welcome

LRF BOOK CLUB

*The LRF Tuesday morning book group will be meeting on May 19, at 11:15 am to discuss **The Woman** by Kristin Hannah.*

We are a warm, congenial group who loves to discuss the book and apply to our lives. Please join us..

Everyone is invited to join in our invigorating discussions. Any questions, please contact Alida Gorin at 908 313 4067

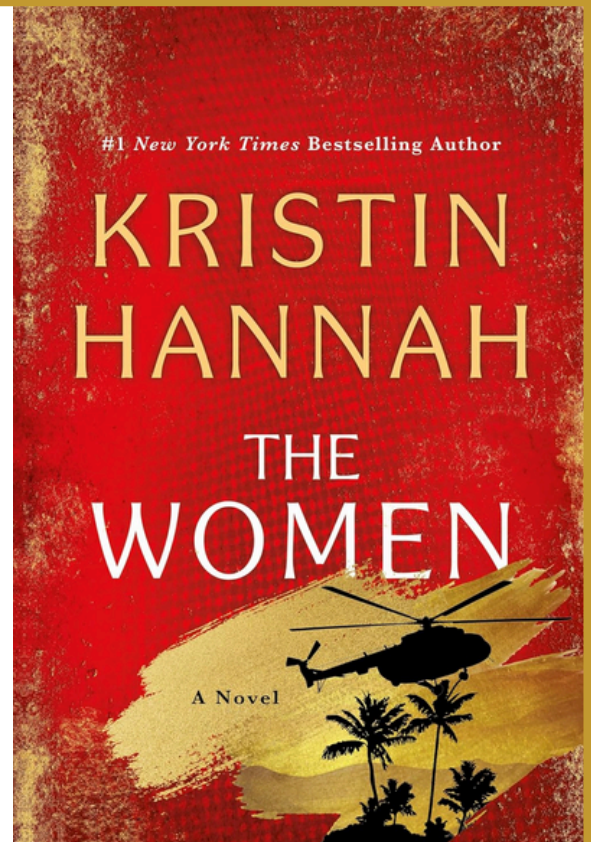

COMMUNITY MANAGER REPORT - CONT'D

BULK COLLECTION PILOT PROGRAM – As you all know, Manatee County launched last year a new program which consolidated all pick-up dates into one day while utilizing a 96-gallon gray garbage bin, which was designed, per Manatee County to “...accommodate increased waste volumes, reduce litter, and support the County waste haulers as they transition to more efficient, automated collection systems.” After the new bin, which is three times the size of an average garbage bin, proved to be problematic due to its size, Manatee County amended the program by exchanging, at no cost, the large 96-gallon bin with a smaller one for those who requested it. With the above in mind, this week, a couple of long-time members of this community shared with us yet another important piece of information regarding this subject matter: a new pilot program Manatee County is launching, starting May 1 . After the new Big Bin Advantage was launched last year, residents who want to dispose of bulk items, which used to be picked up at no charge, had to arrange, for a \$59 fee, of course, for a pickup day with Manatee County Utilities Dept. As a result, complaints from residents led County Officials to reevaluate the subject matter. On its website, Manatee County advised on April 8th, 2026, that:

“The Manatee County Board of County Commissioners has approved the launch of a Bulk Collection Pilot Program by Manatee County Utilities beginning May 1, 2026, expanding curbside bulk pickup service for residents while collecting data to help evaluate future service options. Under the pilot program, residential customers will be able to have two bulk items picked up at the curb on a predetermined scheduled regular service day once per month, for a total of 12 collections per year, with no rate changes at this time. The program will also include one annual bulk collection per property (of up to 10 cubic yards) of the same material... Certain items, including tires and white goods (appliances), as well as the annual large-bulk pickup, will require advance scheduling through the County’s Customer Self-Service Portal at mymanatee.org/css. Household hazardous waste and electronic scrap services will not change as part of the pilot program and will continue to not be collected curbside. Manatee County residents may continue to drop off these materials free of charge at the Lena Road Landfill, and the County will continue offering four remote household hazardous waste dropoff events each year. More information is available at mymanatee.org/hhw.”

We hope you find this information helpful and thank all residents who share such information with the rest of the community.

COMMUNITY RELATIONS COMMITTEE



LAKERIDGE FALLS FLAG BRIGADE



REMEMBERING OUR FALLEN MILITARY MEN & WOMEN BE A PART OF OUR FLAG BRIGADE

Once again to honor and remember those members of the United States Armed Forces who have died in service to our country, we will install American Flags throughout the LRF Community for Memorial Day . Assisting in the installation of our flags is a simple, yet poignant reminder that those who died gave their lives and futures for us and our freedom. Please plan to join us:

WHEN: FRIDAY, MAY 22ND

TIME: 9:00 AM

WHERE: IN FRONT OF THE CLUBHOUSE

BRING: A SCREWDRIVER (TO DIG A PILOT HOLE)



SOCIAL COMMITTEE NEWS



JUDY HALVORSEN (LEFT) AND PEGGY HAYDEN (RIGHT) RECENTLY HOSTED AN INFORMATIVE 'SHARING OUR TRAVELS' EVENING. JUDY TAUGHT US ABOUT TURKEY, AND PEGGY, ARGENTINA. WE THANK YOU!



BINGO
Night

MAY 11
at 6:30pm
LakeRidge Falls Clubhouse
4200 LakeRidge Blvd

SIGN UP NOW

SPICAY POTLUCK

Cinco de Mayo

Fun Food Friends
5 May, 2026
6:00 pm

DIG OUT THOSE GOOD MEXICAN RECIPETS
LakeRidge Falls Clubhouse

Presents

MEMORIAL DAY

POOL

Party Potluck

May 29
4:30 PM
FRIDAY

DESSERTS PROVIDED BY SOCIAL COMMITTEE

NO ALCOHOL OR GLASS CONTAINERS AT THE POOL

May 2026

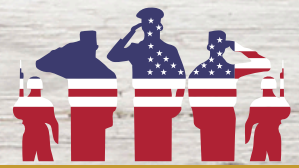

Sunday	Monday	Tuesday	Wednesday	Thursday	Friday	Saturday
<div data-bbox="105 283 251 430" style="border: 2px solid orange; padding: 5px; display: inline-block;"> Read me please! </div> <div data-bbox="259 294 673 430" style="margin-left: 10px;"> <p>NOTE SCHEDULE MAY CHANGE FOR UNFORESEEN REASONS. MAKE SURE TO FOLLOW THE WEEKLY REMINDER FOR UPDATED SCHEDULE SOME OF THE COMMITTEE MEETING MAY NOT TAKE PLACE AS SOME OF THE COMMITTEES MEET AS NEEDED. PLEASE MAKE SURE TO FOLLOW POSTED AGENDAS</p> </div> <div data-bbox="690 378 974 451" style="margin-left: 10px;"> <p>Red - Grand Salon - Green - Activities Room - Blue - Multi Purpose Room</p> </div> <div data-bbox="690 462 1136 493" style="margin-left: 10px;"> <p>* P&M - PILATES & MOVEMENT</p> </div>					<p>1 9:00 Bocce 9:00 Water Aerobics 10:00 Sociable Stitchers 10:00 Water Aerobics Instructor (\$6) 11:30 DINING DIVAS</p>	<p>2</p>
<p>3</p>	<p>4 9:00 Bocce 9:00 Water Aerobics 10:00 Social Committee 1:00 500 Bid 1:00 Tic</p>	<p>5 9:30 Water Aerobics 10:00 Landscape Committee 10:00 Men's Coffee 1:00 Bridge 1:00 Mexican Train 2:00 Water Volleyball 6:30 Euchre 6:00 pm SREAY POLLOCK LakeRidge Falls Clubhouse</p>	<p>6 9:00 Bocce 9:00 Water Aerobics 9:00 Ladies Chat 9:30 Watercolor Art Class 10:00 Women's Bible Study 10:00 Chair Yoga (\$5) 11:00 P&M (\$10) 1:00 Mahjong 2:00 Water Volleyball Pro</p>	<p>7 12:30 Mahjong 2:00 Water Volleyball 3:30 Friends Tai Chi 6:30 Hearts</p>	<p>8 9:00 Bocce 9:00 Water Aerobics 10:00 Sociable Stitchers 10:00 Water Aerobics Instructor (\$6) 2:00 Board Meeting</p>	<p>9</p>
<p>10 </p>	<p>11 9:00 Bocce 9:00 Water Aerobics 1:00 500 Bid 1:00 Tic 1:30 Art League 6:30 </p>	<p>12 9:30 Water Aerobics 10:00 Men's Coffee 11:00 Roads & Grounds Committee 1:00 Bridge 1:00 Mexican Train 2:00 Water Volleyball 6:30 Euchre</p>	<p>13 9:00 Bocce 9:00 Water Aerobics 9:00 Ladies Chat 9:30 Watercolor Art Class 10:00 Women's Bible Study 10:00 Chair Yoga (\$5) 11:00 P&M (\$10) 1:00 Mahjong 2:00 Water Volleyball Pro</p>	<p>14 9:00 Buildings Committee 10:00 ARB 12:30 Mahjong 2:00 Water Volleyball 3:30 Friends Tai Chi 6:30 Hearts</p>	<p>15 9:00 Bocce 9:00 Water Aerobics 10:00 Sociable Stitchers 10:00 Water Aerobics Instructor (\$6) 10:30 Community Relations Committee</p>	<p>16</p>
<p>17</p>	<p>18 9:00 Bocce 9:00 Water Aerobics 1:00 500 Bid 1:00 Tic</p>	<p>19 WOMEN'S BREAKFAST 9:30 Water Aerobics 10:00 Men's Coffee 11:15 LRF BOOK CLUB 1:00 Bridge 1:00 Mexican Train 2:00 Water Volleyball 6:30 Euchre</p>	<p>20 9:00 Bocce 9:00 Water Aerobics 9:00 Ladies Chat 9:30 Watercolor Art Class 10:00 Women's Bible Study 10:00 Chair Yoga (\$5) 11:00 P&M (\$10) 1:00 Mahjong 2:00 Water Volleyball Pro</p>	<p>21 10:00 Security Committee 12:30 Mahjong 2:00 Water Volleyball 3:30 Friends Tai Chi 6:30 Hearts</p>	<p>22 9:00 Bocce 9:00 Water Aerobics 10:00 Sociable Stitchers 10:00 Water Aerobics Instructor (\$6)</p>	<p>23</p>
<p>24</p>	<p>25 9:00 Bocce 9:00 Water Aerobics 1:00 500 Bid 1:00 Tic MEMORIAL DAY </p>	<p>26 9:30 Water Aerobics 10:00 Men's Coffee 1:00 Bridge 1:00 Mexican Train 2:00 Water Volleyball 6:30 Euchre 7:00 Wine & Fiction Book Club </p>	<p>27 9:00 Bocce 9:00 Water Aerobics 9:00 Ladies Chat 10:00 Pool Committee 10:00 Women's Bible Study 10:00 Chair Yoga (\$5) 11:00 P&M (\$10) 1:00 Mahjong 2:00 Water Volleyball Pro</p>	<p>28 12:30 Mahjong 2:00 Water Volleyball 3:30 Friends Tai Chi 6:30 Hearts</p>	<p>29 9:00 Bocce 9:00 Water Aerobics 10:00 Sociable Stitchers 10:00 Water Aerobics Instructor (\$6) 4:30 PM </p>	<p>30</p>



Combined 55+ Years of Real Estate Experience

We Create Real Estate Solutions for You!

(941) 725-0911

Marie@EasyListing.com



Marie Avery-Withers
 Danny Withers
 Your Neighborhood REALTORS®

What your neighbor said: *"Thanks for your excellent help. I'm so pleased with the outcome. I chose the right people to sell my home!"*

Thinking About Making a Move?

BradentonRealEstate.com



FREE LIVING WILL

WITH EVERY ESTATE PLAN

Simple Will	\$195.00
Revocable Living Trust:	
Single, Non Taxable	\$1,195.00
Married, Non Taxable	\$1,795.00
Power of Attorney	\$150.00
Health Care Surrogate	\$130.00

No additional Costs required other than filing fees, if applicable

Dana Laganella Gerling, Esq. Rodney Gerling, Esq.

Marla Stewart Owczarek, Esq

6148 State Road 70 Bradenton, FL 34203

941-756-6600

WWW.GERLINGLAWGROUP.COM

Some of Our Achievements



Our Services



Estate PLANNING



PROBATE



Trust ADMINISTRATION





Elder LAW

**SUPPORT OUR
ADVERTISERS**

HomeSmart
Inspections





RESIDENTIAL
PROPERTY INSPECTOR

HABLA ESPAÑOL

DAVIDE FERRIOLO
General Manager

941.413.6600
David@HomeSmartInspections.Net
HomeSmartInspections.Net
License # HI16286

InterNACHI
CERTIFIED PROFESSIONAL INSPECTOR
CPI

FIRST TIME HOME BUYER FRIENDLY



GULF SHORE
Physical Therapy Center



Tony Teresi, PTA, CPT



Antoinette Ohlson, PT

FIRST SESSION FREE for LakeRidge Falls Residents

Pain Relief Starts Here – Try Shockwave Therapy FREE!

Dealing with stubborn pain that just won't go away? At Gulf Shore Physical Therapy Center, we're offering your FIRST Shockwave Therapy session FREE!

- ✓ Fast, non-invasive treatment
- ✓ Proven results for chronic pain & injuries
- ✓ Get back to doing what you love- pain free

Evidence based, FDA Registered device. Safe, effective, and no down time.

Perfect for: · Plantar Fasciitis · Tennis & Golfer's Elbow · Shoulder Pain · Knee/Hip Pain · Achilles Tendonitis

- 📍 Don't wait - spots are limited!
- 📞 Call today to book your FREE first session!

941-355-5565

➡ Experience the Difference ➡
at Gulf Shore Physical Therapy Center!
GulfShorePT.com